

SIMPLE SHUTTLE SS1A

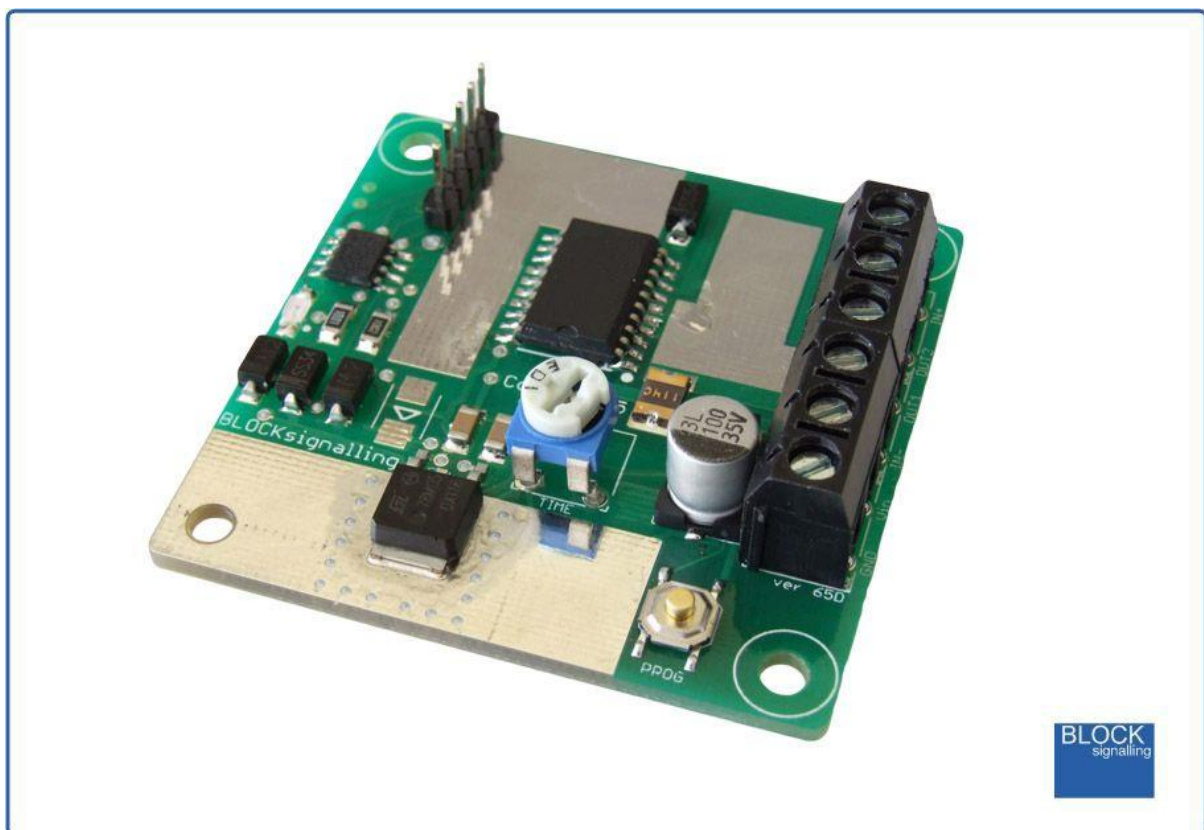

Simple Shuttle Train Controller with Adjustable Delay

- Automatically operates a model train backwards and forwards along a single track
- Waiting time at the ends can be varied with a simple screwdriver adjustment
- An led on the PCB shows when the direction of the train is forwards
- Microprocessor controlled for accuracy
- Simple wiring and operation

The BLOCKsignalling Simple Shuttle is designed to automate a DC model train running backwards and forwards along a single length of track.

At each end of the track, a diode is fixed across an insulated rail gap to stop the train until the track current is automatically reversed by the module and the train will start traveling in the opposite direction.

The time between each change in current direction can be changed by a simple screwdriver adjustment. The delay time for each direction is adjustable between 1 second and 10 minutes.

Rated for traction current up to 1A.

Power Supply

The module operates from any DC supply in the range 7V DC to 25V DC, or any AC supply in the range 7V AC to 16V AC.

If the track voltage is above 7V DC, then the module can be connected to the track power supply. Please see wiring diagrams below for details.

DCC track power can also be used to feed the module (although the module can only power DC trains).

Timing Adjustment

The timing is adjusted with a small screwdriver, which fits into a slot in the adjuster mounted on the PCB.

The adjustment is very fine for the first half of the rotation, setting the timing between 1 second and 90 seconds, then becomes more coarse up to the maximum setting of 10 minutes.

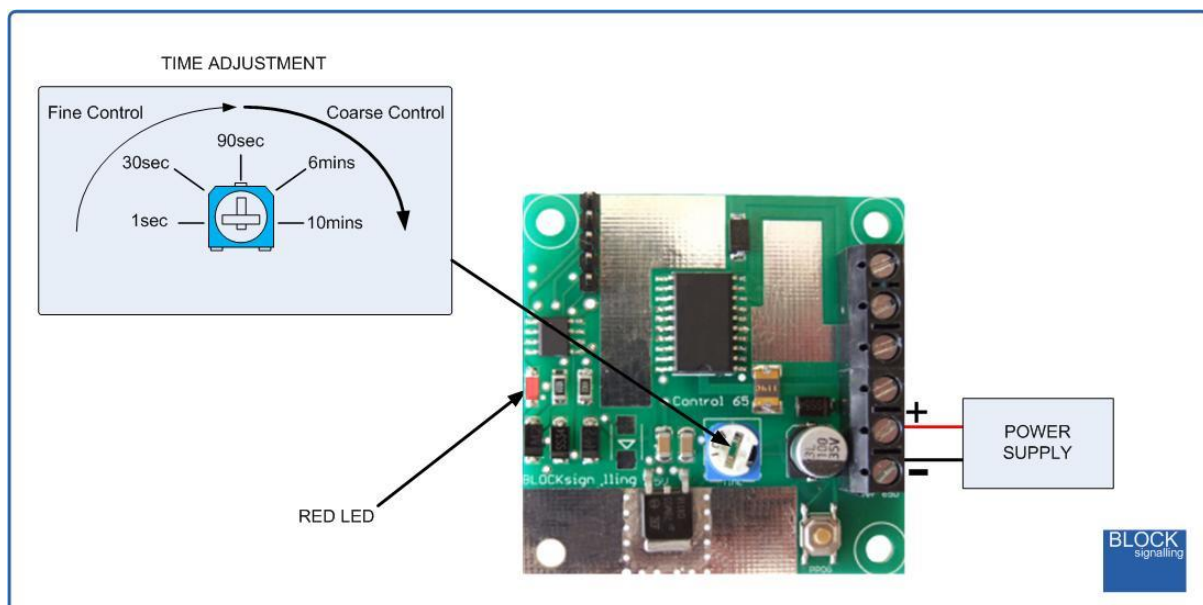

The module reads the setting when the power is applied, and each time the direction changes.

Generally, it is easiest to set the approximate time using the diagram above, then switch off the power for 10 seconds or so. When the module is re-powered, it will read the setting and commence its operation.

Minor adjustments can be made whilst the unit is running, and they will be used at the next opportunity.

Connecting Up

At each end of the track, a small break is required, to allow diodes to be connected (these are included with the module).

When the train passes the break in the track, the diode prevents traction current reaching the train until the polarity is reversed by the module.

The led on the pcb lights when the direction of travel is from west to east.

If the train is operated on a feed of greater than 7V DC, then the module can use the same supply as the track feed.

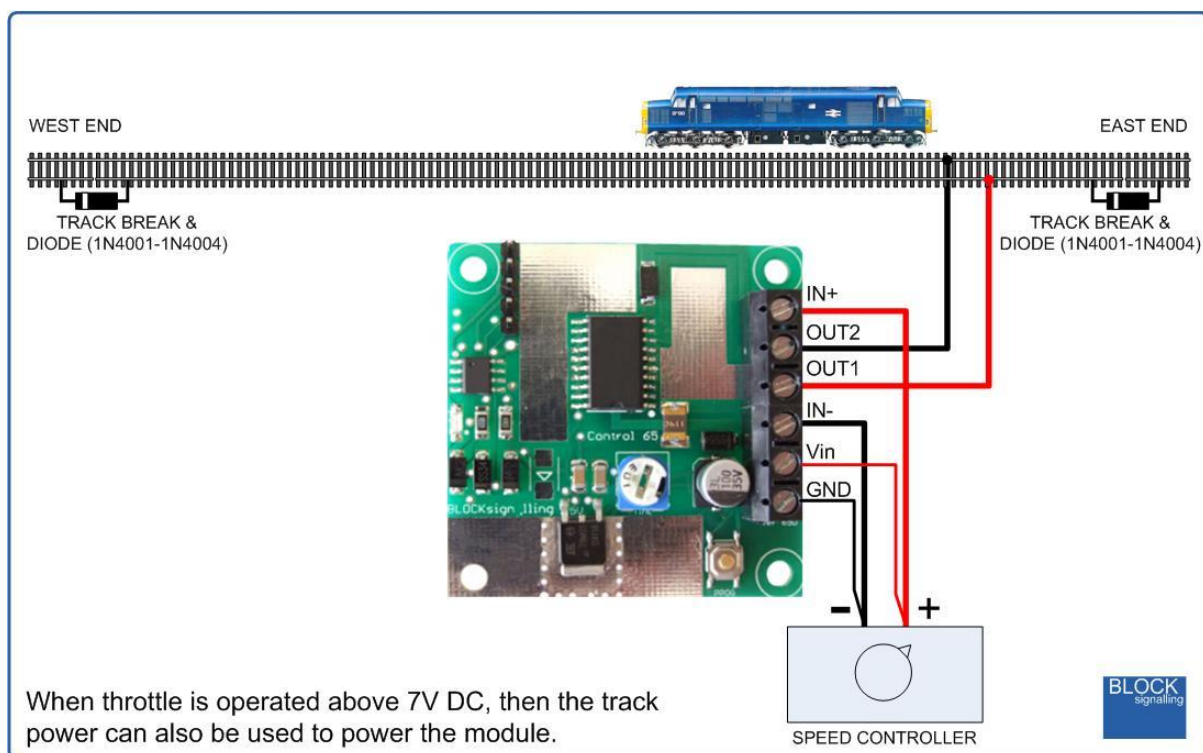

For smaller models, where the track supply is below 7V DC, a separate power supply is required for the module. This can any DC supply in the range 7V DC to 25V DC, or any AC supply in the range 7V AC to 16V AC.

The power controller 16V AC auxiliary supply output is suitable. If there is a DCC supply available elsewhere on the layout, then this could also be used to power the module.

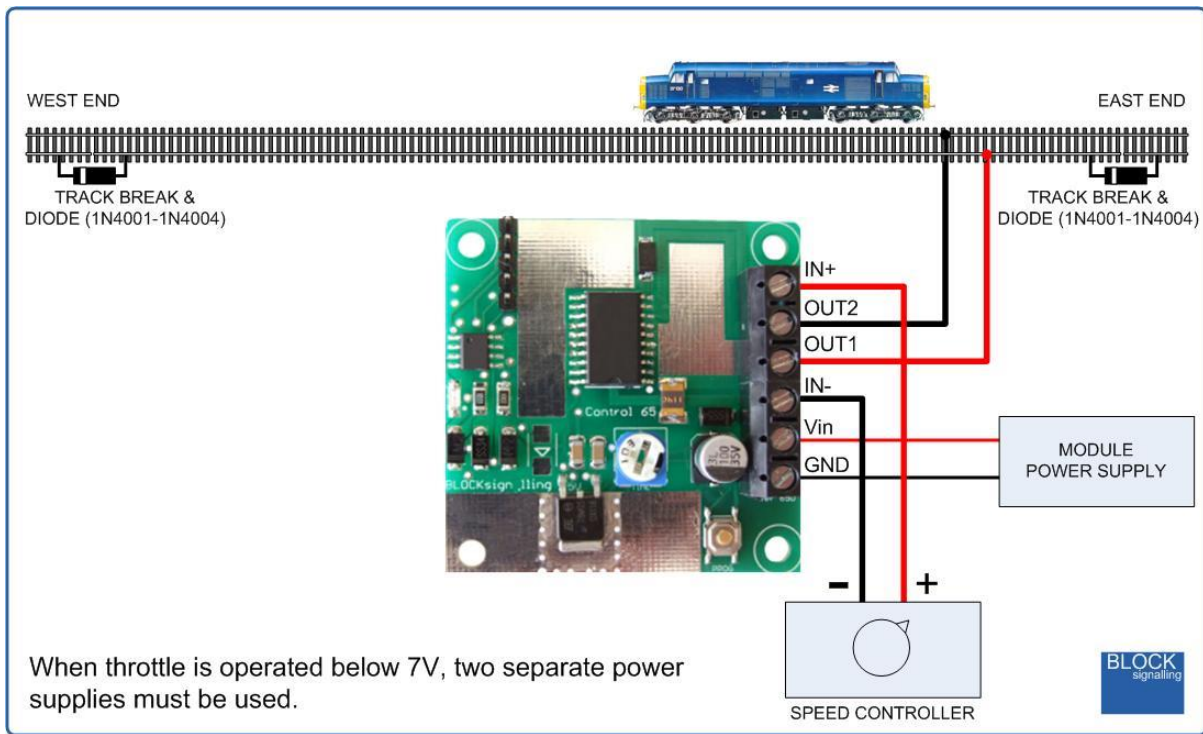

Other Ideas

You can use one low cost speed controller to run several shuttle units, providing they are within the capacity of the controller.

Trains can be operated at different speeds by inserting one or more diodes in the feed to the track. Each diode has an approximate 0.7V voltage drop.

Use a different number of diodes in each direction to create different speeds in each direction. You need at least one diode for each direction.

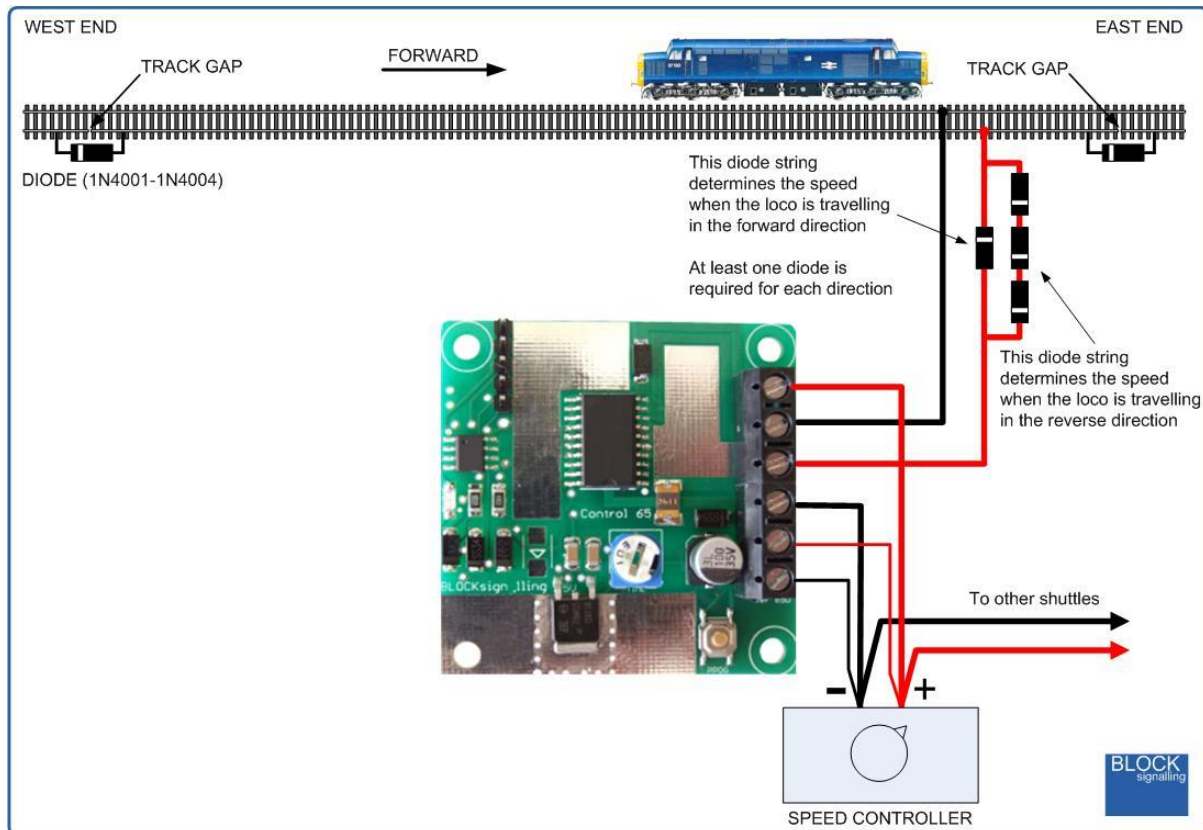

Creating additional track gaps, with associated diodes, allows differing voltages along a length of track, and so different operating speeds in each section.

Use one diode in each direction to drop the speed in the following section by equal amounts.

Use a different number of diodes in each direction to create different speeds in each direction. You need at least one diode for each direction.

Speed reductions can be removed by shorting across the diodes with a switch.

Different stop points can be created by inserting additional single diodes, and shorting across them when they are not required.

