

POINTS POSITION INDICATOR PPI5

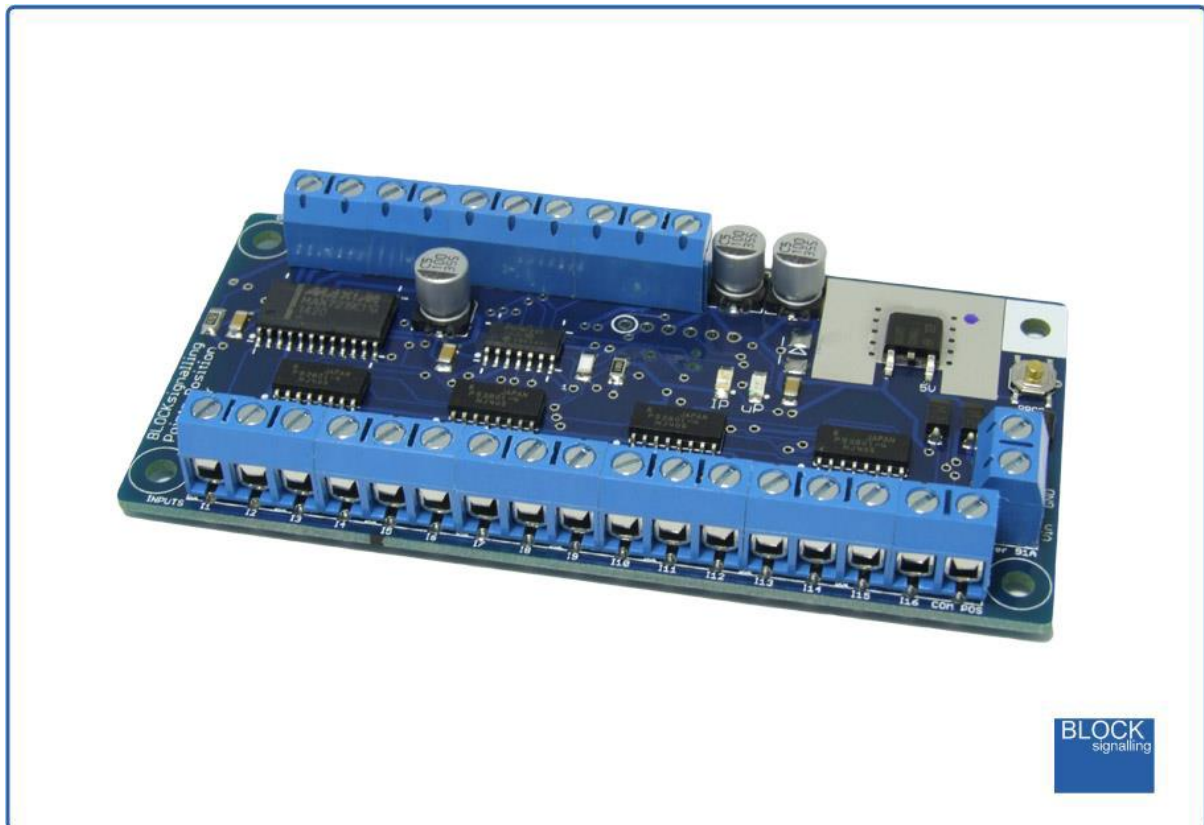

Advanced PPI with Adjustable LED Brightness

- Monitors the brief positive operating voltage across points motors when they are switched
- Lights a corresponding led on a control panel to show the last operation of each set of points
- Saves all settings automatically to memory when the power is switched off
- Monitors up to 8 sets of points
- Adjustable led brightness
- No resistors are required simplifying wiring
- Opto-isolated inputs accept voltages from +5V to +60V

The Points Position Indicator (PPI) monitors the brief switching voltage to either of the two coils of a points motor, and displays the last operation using coloured leds which can be mounted on a route mimic.

Manual methods to switch points include simple spring-loaded switches, push buttons, probe and stud.

This PPI is designed for operation on systems where the coil **common is POSITIVE**, such as when points are driven from DCC Accessory decoders, the decoders most often provide a voltage of around +12V supply to the common of the points coil, and then switch the other connections of the coils to ground to switch the points.

The microprocessor controls the led brightness and so no resistors are required, simplifying wiring up.

Power Supply

The controller is designed for use with a DC power supply of between 10V and 25V, or an AC power supply of between 10V and 16V.

If a DC power supply is connected with incorrect polarity, no damage will occur.

Where there is a choice, the recommended power supply is 12V DC.

The power consumption is approximately 50mA with eight leds lit.

Operation

The PPI can monitor 8 pairs of points using its 16 input channels numbered I1 to I16.

Each input is able to control an led on the output (see wiring diagrams below).

A negative voltage on an input causes the associated output led to switch. Also, at this moment the other led of the pair is switched off.

In this way, only one of the output leds is lit at any one time, that being the one with the most recent negative input voltage pulse. This means that only one of the route leds for each channel will be lit at any one time.

Each time an input change occurs, it is stored in memory, so that when the power is switched off and on again, the led outputs are set automatically to their last recorded condition.

Connecting the Unit

Simply connect one of the PPI input terminals to one end of one of the point's motor coil, the other input to the end of the other coil, and the common of the coils to the COM POS input to the PPI.

Only one connection from a coil common to the COM POS terminal of the PPI is required. This allows the coil voltages to be recognised by the PPI correctly against this reference.

Each time the points are operated the yellow led on the pcb will briefly light. Most of the time this led will be extinguished.

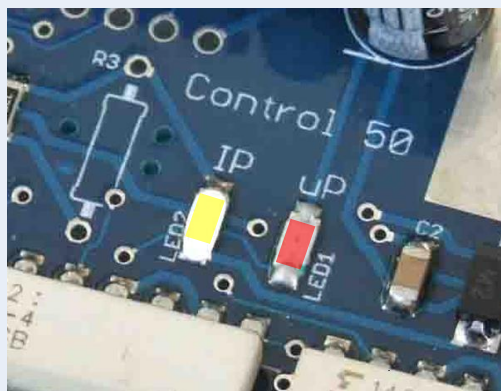

YELLOW LED (IP)– flashes when points change appears on any input terminal

RED LED (uP) – flashes when microprocessor records change in any points position from that held in memory

The PPI also requires a power supply to operate the output leds and power its own circuitry.

If using a DC supply, take care to connect the positive and negative leads correctly. No harm will be done to the PPI if they are connected in reverse, but the PPI will not function.

When powering up, the uP (red) led on the pcb will light (and remain lit) whilst the microprocessor is running. Each time a point is operated, the IP (yellow) led flashes to confirm the input signal.

If the points position has changed, the (red) uP led on the flashes to indicate that the updated status has been stored in memory.

Important:

Keep the wiring to the control panel leds separate from the points wiring.

This prevents possible high currents from the points wiring from interfering with the low level signals feeding the leds and possible damage to the PPI module.

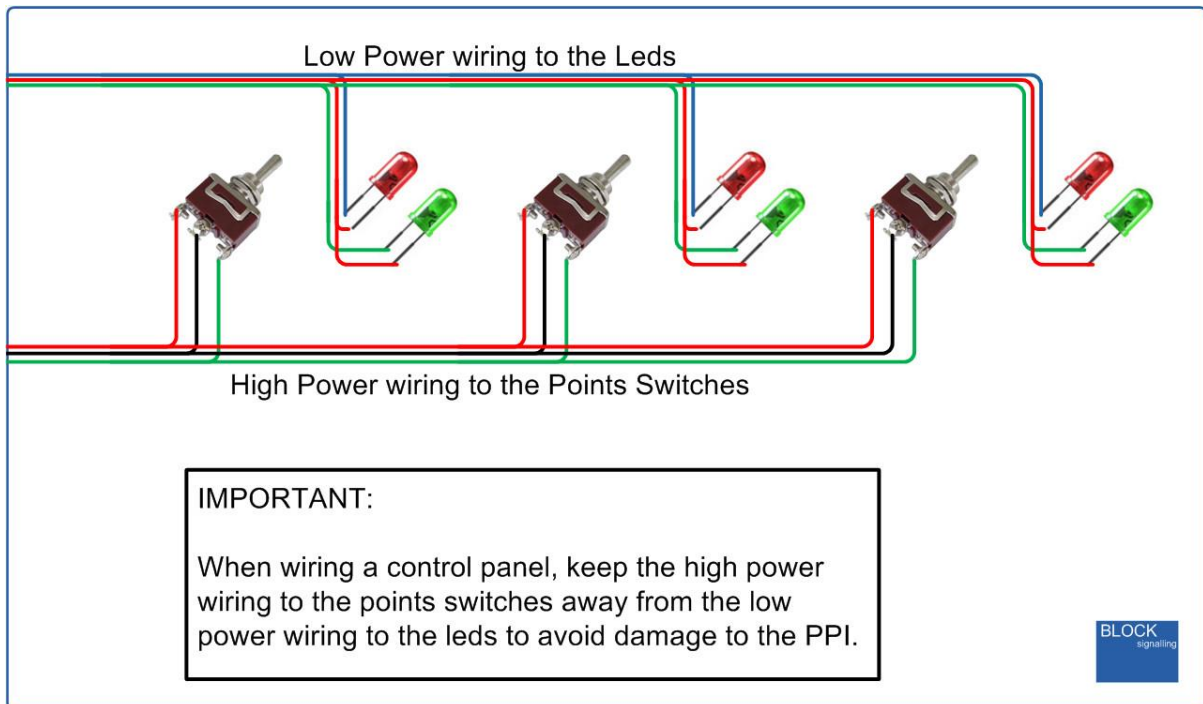

Led Connection

When connecting leds it is important to connect them the right way around.

The negative lead (cathode) is identified by a flat on the side of the led body, and by having a shorter lead.

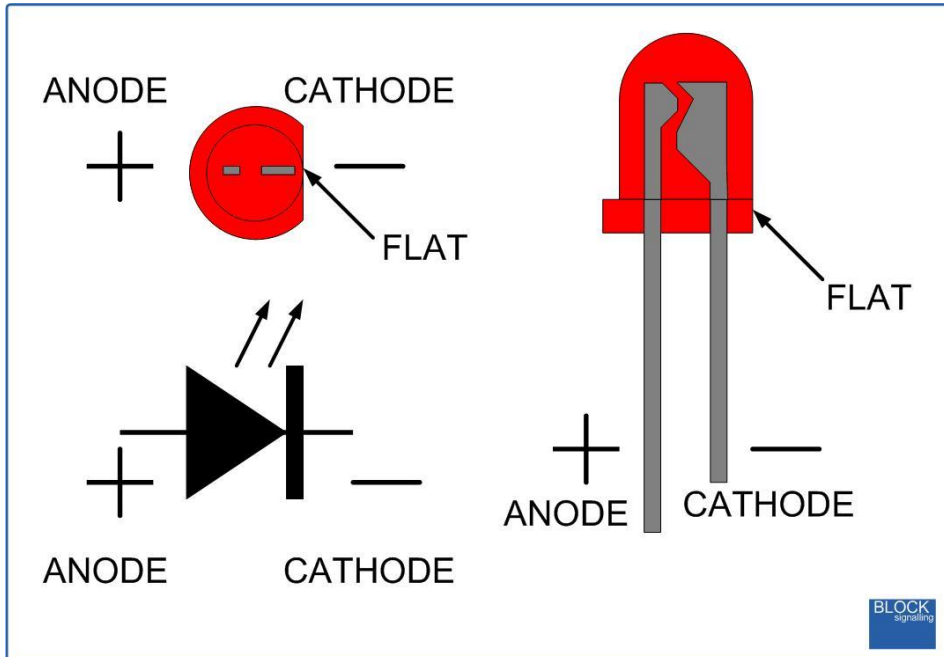

The red and green leds share the same output, so for instance, the first set of points are represented by a red and green led with their anodes connected to terminal A1+.

All the green led cathode connections are wired to the C1- terminal.

All the red led cathode connections are wired to the C2- terminal.

If the output leds are incorrectly connected in reverse they will shine very brightly and will fail after a brief period. This may also damage the PPI module.

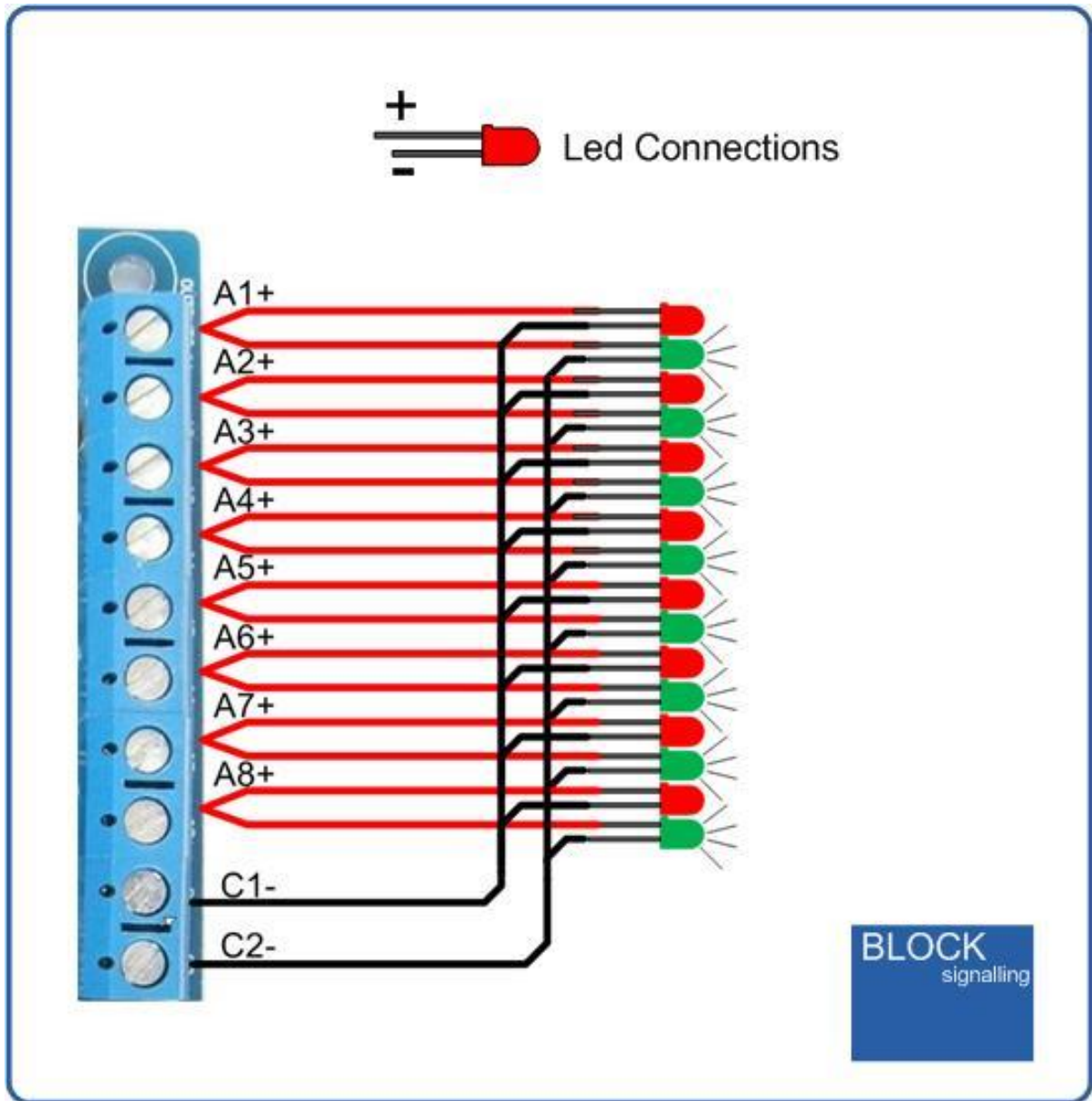

Following factory testing, sometimes more than one led will be lit. This will clear as soon as each set of points is first operated.

System Wiring

The diagram below shows the connections to one set of points. In practice, connections to the PPI will normally be made at the control panel so that the wiring length can be kept to a minimum.

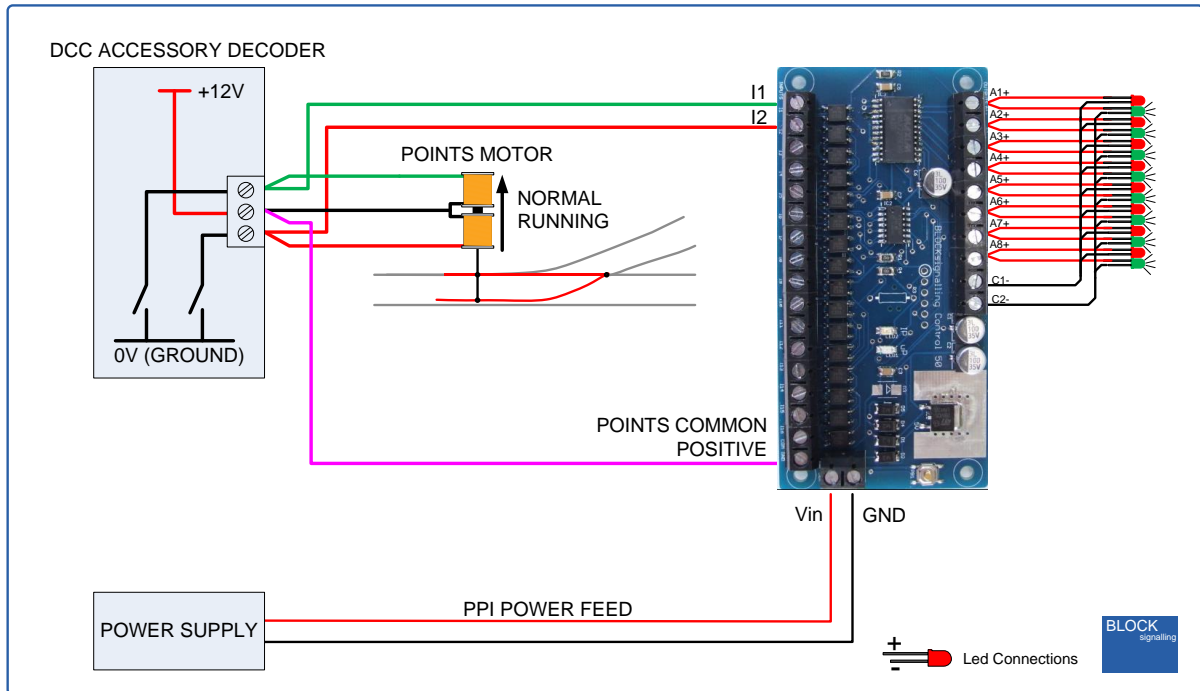

Programming

There is no necessity to reprogram the PPI, but there are a small number of adjustments available to the user.

Programming is performed by holding down the Push Button when switching on the power.

The red led on the PCB flashes at 1 second intervals. When the required number of flashes is seen (see the diagram for the list of possible choices) the button is released to store the first value. At this point the led comes on for five seconds to confirm the value is stored.

The led then starts flashing again, and this time the button needs to be pressed to store the second value.

Once the two values to be stored are entered, the led flashes 10 times rapidly, and the module starts operating.

If the programming is aborted by switching off, then the programming must be repeated.

Following the diagram is an explanation of the settings.

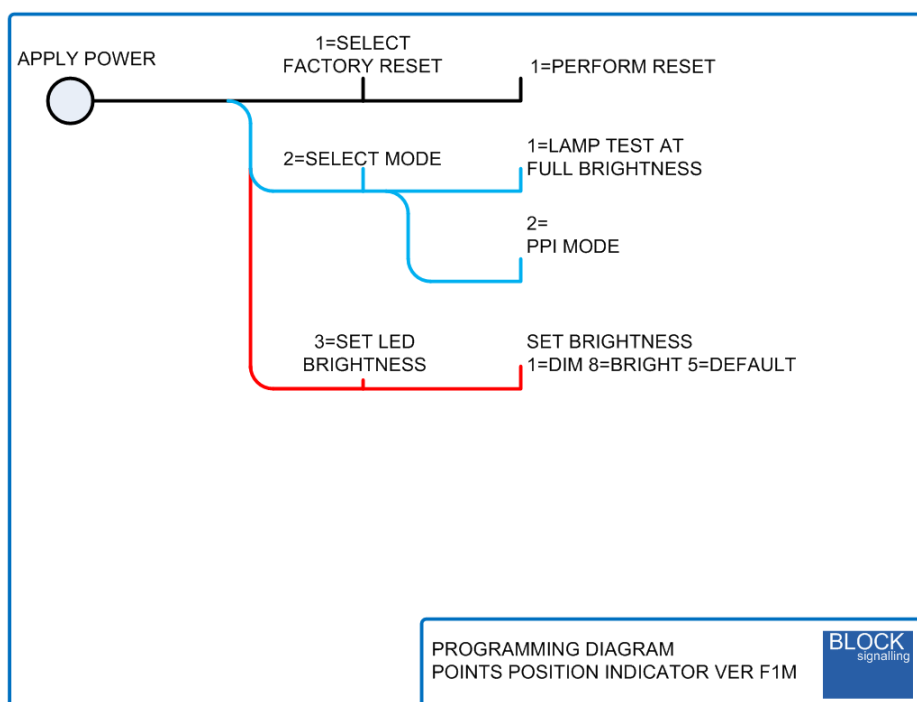

1. Troubleshooting the PPI

If you are having a problem getting the PPI to work as you expect, this part of the document should help. Each PPI is tested before shipping, so it is unlikely the module itself is at fault but this document should allow you to check for correct function of the module, power supply and external wiring.

First to the basics, with all the wiring disconnected from the module, just leaving the two power connections, switch the power supply on.

The red led on the PCB should flash and then stay on steady. This shows that an acceptable power feed has been connected and that the microcontroller and led driver chips are functioning correctly.

The yellow led should be off. This led only lights when the points are operated and should be off at all other times.

If you don't see the red led, check the polarity of the connections to the module, and that the power supply is within the correct range (10V to 25V DC). An AC power supply can also be used, but for these tests a DC power supply is used to keep things simple.

Using a DC supply, the power connections must be the correct polarity. If they are reversed, the module will not function (the red led on the PCB will not light). The module will not be damaged by this, but it will just not operate at all.

MICROPROCESSOR BASIC FUNCTION

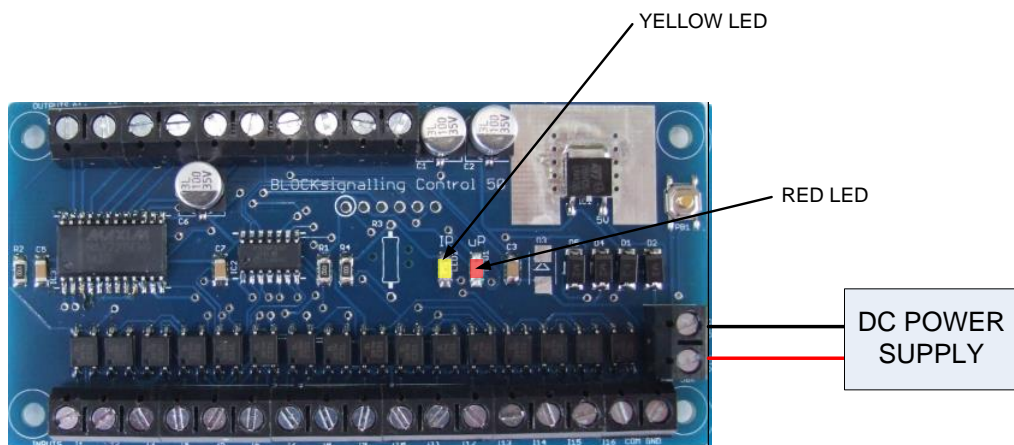

1. CONNECT POWER SUPPLY (BETWEEN 10V AND 25V DC)
2. RED LED ON THE PCB LIGHTS AFTER 1 SECOND
3. RED LED STAYS LIT
4. YELLOW LED REMAINS EXTINGUISHED

2. Testing the Points Inputs

The connections to the points are electrically isolated from the control electronics within the PPI, so the main PPI power feed is not required for this test.

Using a DC supply of around 12V (this test will work with a voltage between 5V and 25V), connect the positive side of the supply to the COM POS terminal and using the other wire, connect it to each input terminal in turn.

Each time you connect the wire to an input terminal, the yellow led on the PCB should light.

When there is no connection to an input terminal, the yellow led should be extinguished.

One important point here is that there are two models of PPI, one with a negative common (marked COM GND) and one with a positive common (marked COM POS). This diagram is for the one with a common positive connection (it has a COM POS terminal).

Be sure to connect the appropriate polarity of the supply to the common terminal of your PPI.

If the yellow led does not light, swap the polarity of your cables and try again.

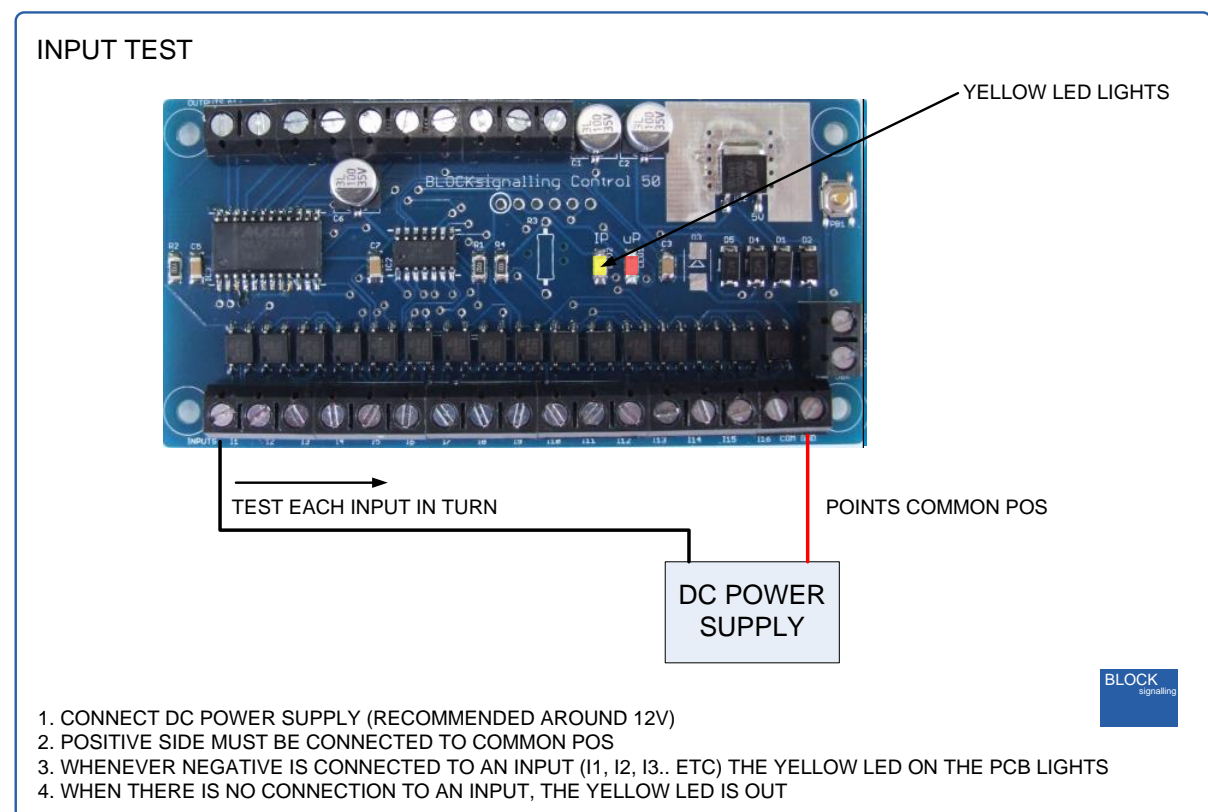

3. Testing the Outputs

The outputs of the module will operate without any of the points wiring connected. Connect two test leds to the I1 and I2 outputs observing the led polarity. No resistors are necessary.

When you apply power to the module, all the output leds will flash on and off for about a second.

After this initial flashing sequence, either one or both leds will be lit at each output. Which is lit (or whether both are lit) depends on what tests were performed on the module during manufacturing.

Other than during the initial flashing stage, there will always be at least one output led lit.

If you don't see the initial flashing, it may be that your leds are wired the wrong way around. In this instance they will be lit particularly bright, and in fact may be irreparably damaged. This can also damage the led driver chip on the PCB such that no connected leds will light up at all.

To summarise:

Switch on the power. The red led on the PCB should flash and then stay on permanently.

All connected leds should flash when the power is applied, and then at least one on each output should remain on.

OUTPUT TEST

The diagram shows a blue PCB labeled 'BLOCKsignalling Control 50'. It features two rows of terminals: 'OUTPUTS' at the top and 'INPUTS' at the bottom. A power supply is connected to the bottom terminals. Two test LEDs (one green, one red) are connected to the top terminals. A red LED on the PCB is highlighted with a red arrow and labeled 'RED LED'. A legend shows a red LED symbol with a '+' sign and the text 'Led Connections'. A box labeled 'POWER SUPPLY' is connected to the bottom terminals.

1. CONNECT POWER SUPPLY (BETWEEN 10V AND 25V DC)
2. RED LED ON THE PCB LIGHTS AFTER 1 SECOND AND STAYS ON
3. ONE OR BOTH OF THE CONNECTED LEDS LIGHTS

4. Testing the Memory Function

This test is the final check that the module is operating correctly.

It repeats the previous tests, but confirms that the microprocessor on the PCB memorises when points are changed.

Connect up output leds (one pair are shown on the diagram below).

Apply the power and both the output leds and the PCB red led should flash. The PCB led will then remain lit permanently.

As before, one or both of the output leds will be lit.

With a common connection made as in the diagram below, connect the remaining wire to the I1 and I2 terminals in turn.

Each time a connection is made, the yellow led on the PCB should light. Also, the red led on the PCB should briefly extinguish if a different input terminal is connected. This is to indicate that a change has been noticed by the module, and the new state of the point has been recorded in memory.

With each input change, one of the leds on the output will extinguish and the other led will light.

When the alternate input connection is made, the second led will extinguish and the first will illuminate again. If you see this, the module is operating correctly.

FULL TEST

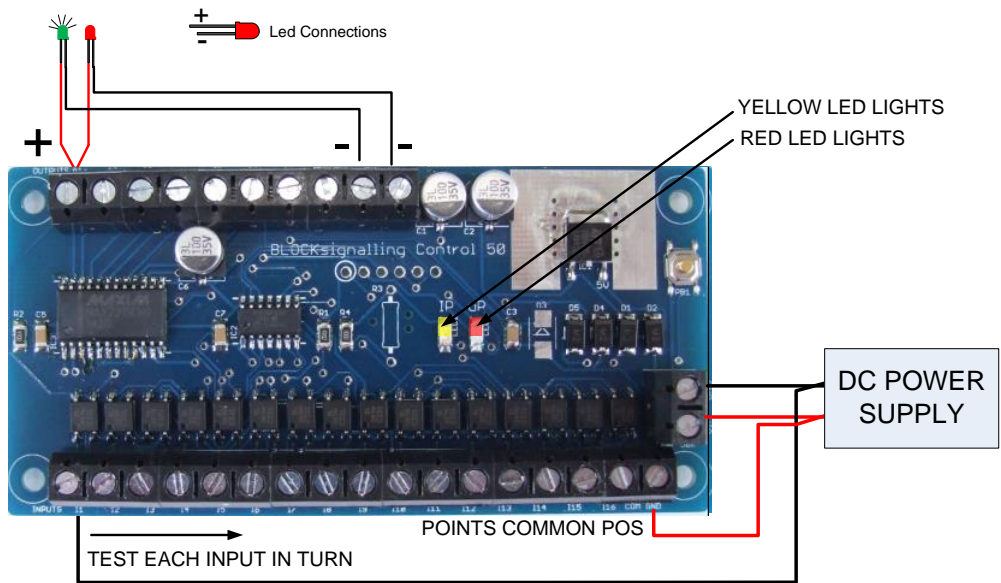

1. CONNECT UP POWER SUPPLY AND LEDS ON THE OUTPUT
2. CONNECT DC POSITIVE TO POINTS COMMON POS
3. ONE OR BOTH OUTPUT LEDS WILL BE ON
4. MOVE INPUT WIRE FROM I1 TO I2
5. RED LED ON THE PCB MAY BRIEFLY GO OUT
6. Q2 LED WILL LIGHT. Q1 LED WILL EXTINGUISH
7. MOVE INPUT FROM I2 TO I1
5. RED LED ON PCB MAY BRIEFLY GO OUT
6. Q1 LED WILL LIGHT. Q2 LED WILL EXTINGUISH
7. REPEAT FOR OTHER PAIRS OF LEDS (ONLY ONE PAIR SHOWN IN THE DIAGRAM ABOVE FOR CLARITY)

5. "Lamp Test"

This test turns off all the leds, then lights them one at a time to check that the leds operate correctly.

With the power on the module, press the push button.

All the control panel leds will extinguish, then only the led connected to A1/C1 will light.

This led will stay lit for 1 second, then extinguish. Then led A2/C1 will light. This sequence is continued until all the leds connected to C1 have lit in turn.

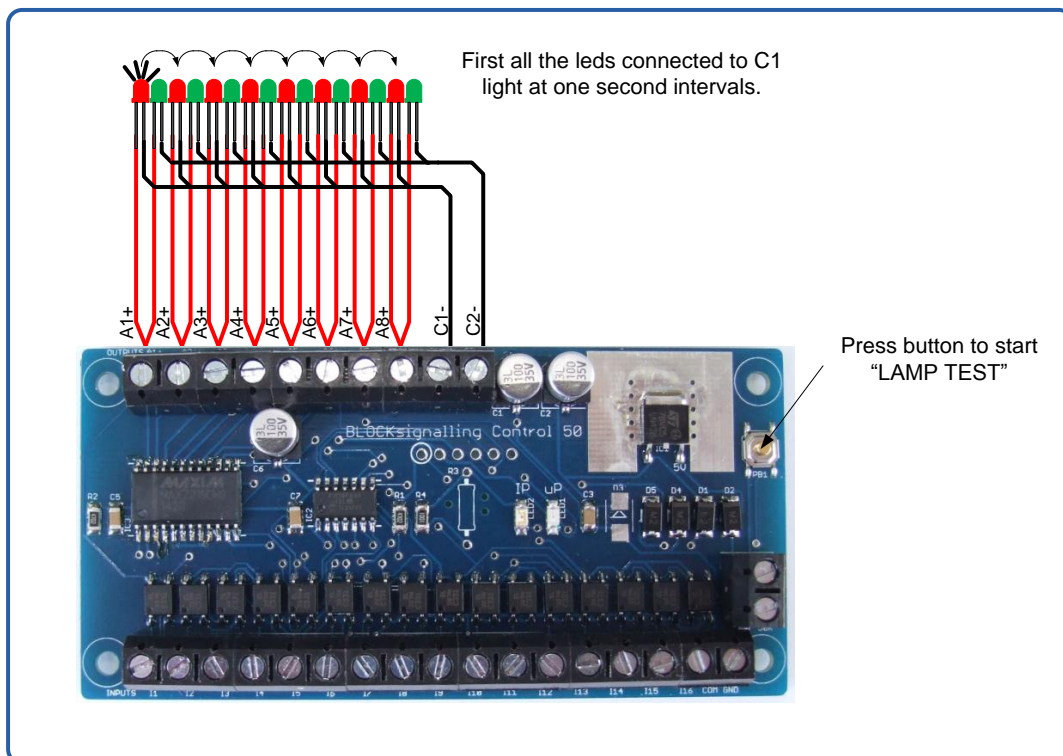

The sequence then continues with the leds connected to A1/C2, then A2/C2, etc, with the last led being A8/C2.

The module then restarts (all the leds flash on and off together during the restart).

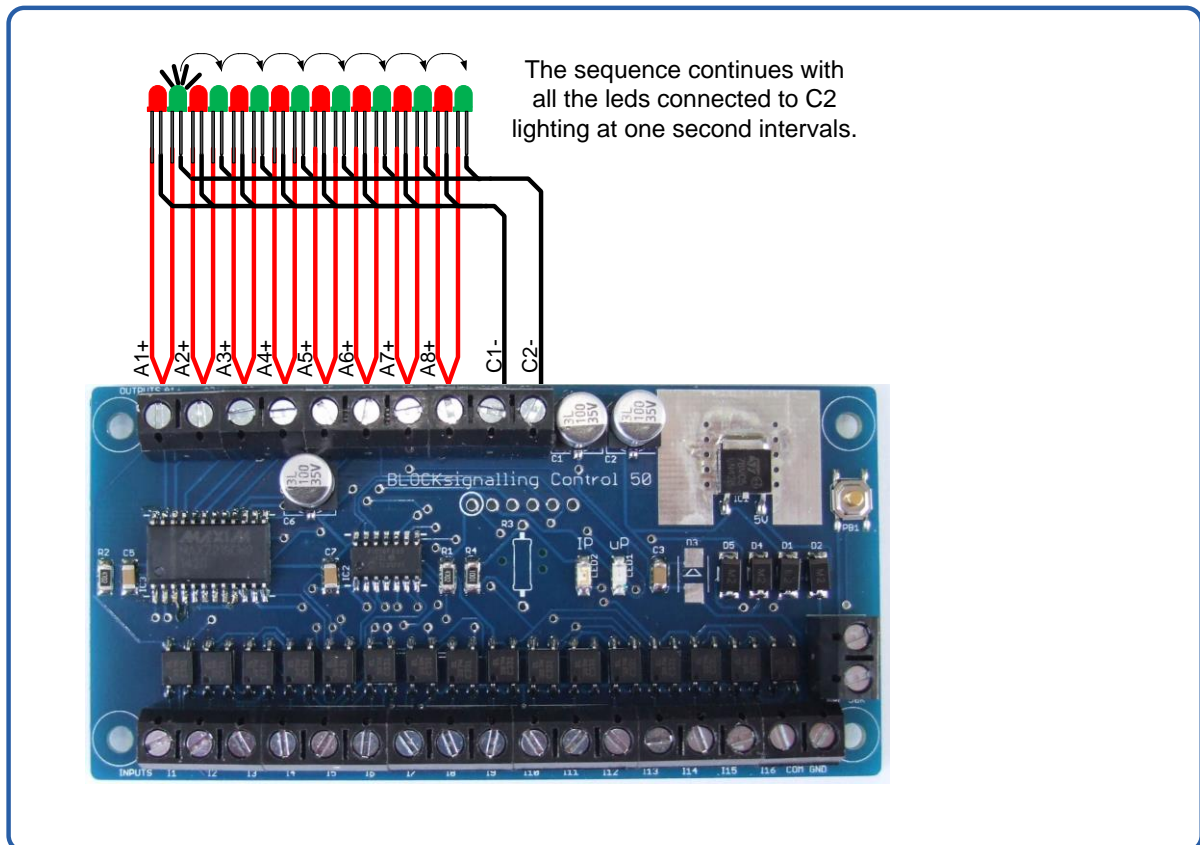

If leds stay lit, when they should be extinguished, then it is likely that are wired in reverse.

This can damage the PPI module and the leds and so the power must be turned off and the wiring corrected.